

# Alstom's Tidal In Stream Energy Converter Demonstration Project

WREC 2011

Philippe GILSON

Bali, October 17<sup>th</sup> , 2011

POWER

**ALSTOM**

## Alstom in Ocean Energy

Alstom's Tidal In Stream Energy converter : BELUGA 9

BELUGA 9 demonstrator status

# Alstom : Four sectors (as of July 4<sup>th</sup> 2011)



**Grid**

24%

**Transport**

24%



**Renewable  
Power**

9%

**Thermal  
Power**

**Sales by Sector (proforma figures)**

43%

Source: Alstom2010/11

**Hydro, Wind, Other Renewables**



**Gas, Steam, Nuclear, PAC**



Alstom tidal demonstration project – WREC - Oct 17, 2011 - P 3

© ALSTOM 2011. All rights reserved. Information contained in this document is indicative only. No representation or warranty is given or should be relied on that it is complete or correct or will apply to any particular project. This will depend on the technical and commercial circumstances. It is provided without liability and is subject to change without notice. Reproduction, use or disclosure to third parties, without express written authority, is strictly prohibited.

# Alstom competencies for Ocean Energy



## ALSTOM HYDRO



## ALSTOM WIND

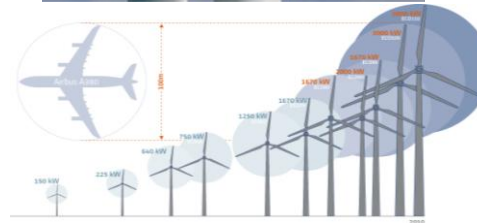

## ALSTOM GRID



**Tidal  
In  
Stream  
Energy  
Converter**



**Wave  
Energy  
Converter**

# Tidal Stream technology selection



**Reliability & reduced maintenance**

**Social & Environmental acceptance**

**Economies of scale**



Only one rotating part

Completely submerged

Growth potential



**Clean Current**  
Renewable Energy Systems

**Technology licensed from Clean Current Power Systems**

# Wave Energy technology selection

**Availability**

**Social &  
Environmental  
acceptance**

**Economies of  
scale**

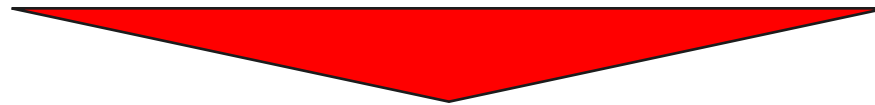

Modular concept  
Dry air circuit

Off-shore deployment

2.5 MW / unit  
Low mass per MW



**40% Investment in AWS Ocean Energy Ltd (Scotland)**

## Alstom in Ocean Energy

### Alstom's Tidal In Stream Energy converter : BELUGA 9

## BELUGA 9 demonstrator status

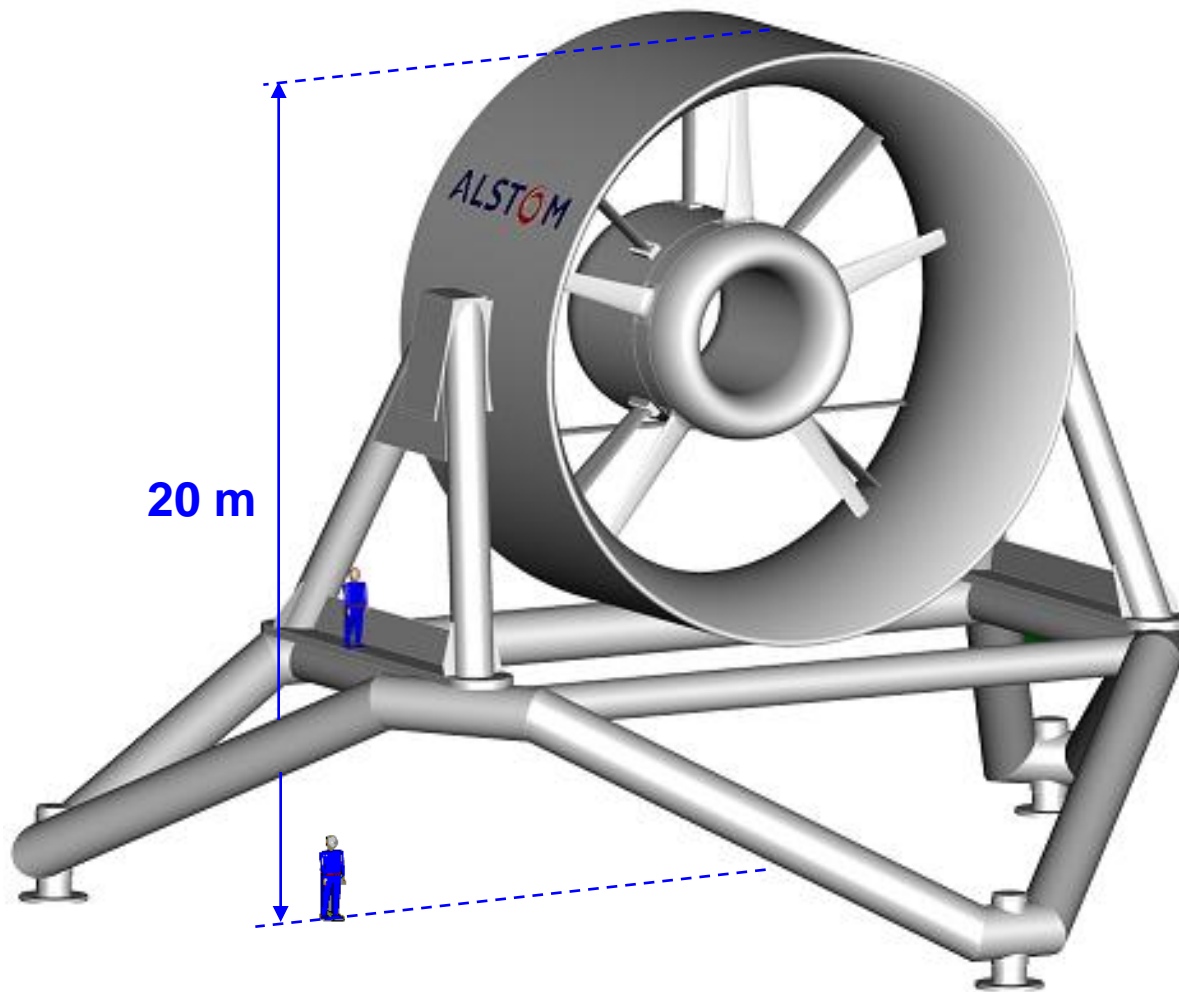

## BELUGA 9

- Power = 1 MW @ 3,5 m/s
- Reversible operations
- Outer diameter = 13 m
- Permanent Magnet Generator
- Variable speed < 50 rpm
- Fixed blades
- Sea water lubricated

## **BELUGA 9** (up to 9 knots)

## Alstom in Ocean Energy

### Alstom's Tidal In Stream Energy converter : BELUGA 9

#### BELUGA 9 demonstrator status

# BELUGA 9 Demonstrator status



## Design studies

Completed

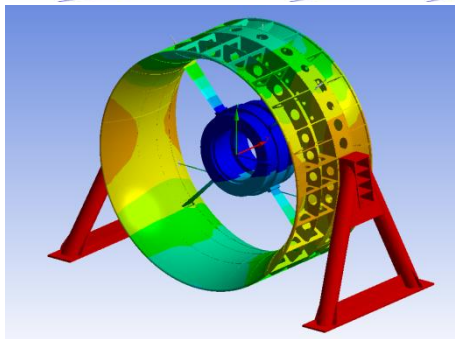
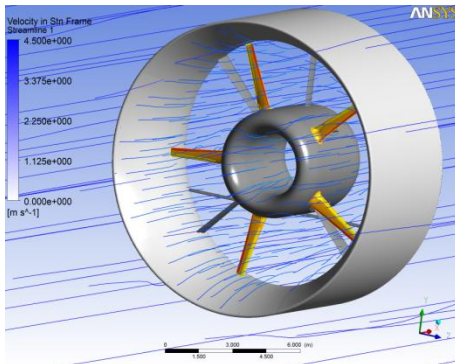

## Scale models tests

Completed

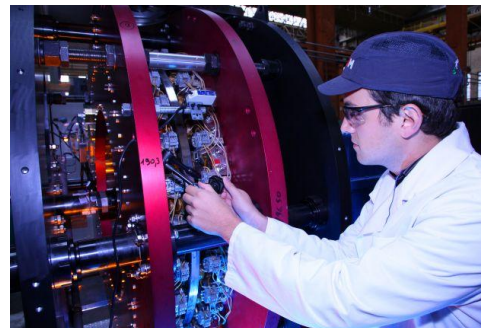

## Full scale fabrication

In progress



**Design validated - Fabrication ongoing**

- Factory tests of the full scale demonstrator
  - Shaft and bearings tests
  - Generator tests
  - Control & Condition Monitoring systems validation

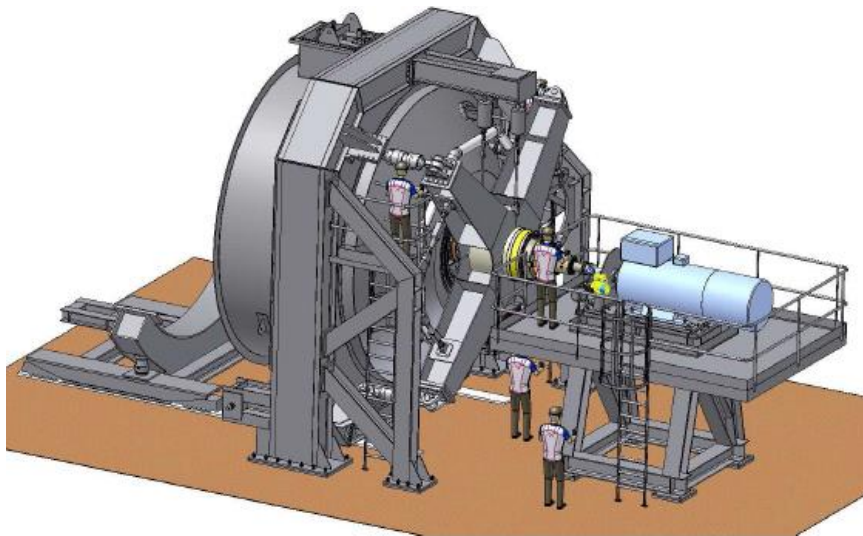

## First landbased full scale TISEC test facility

# BELUGA 9 Demonstrator status

- Deployment at sea in 2012
  - Bay of Fundy, Canada
  - $V > 3.5$  m/s
  - Depth = 50 m
  - Project supported by SDTC

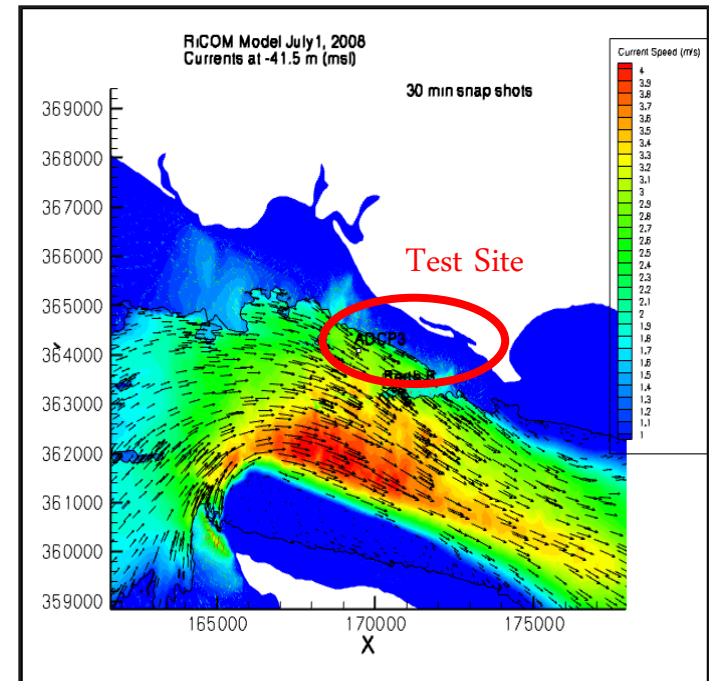

## Pilot tidal farm

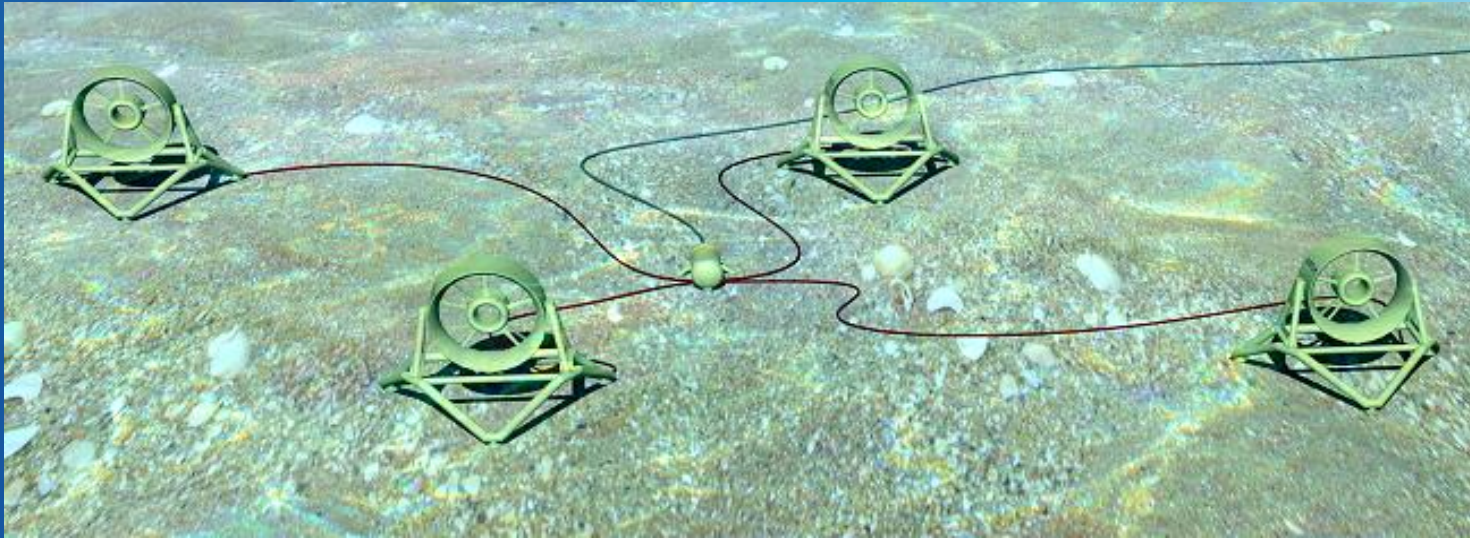

[www.alstom.com/power](http://www.alstom.com/power)

POWER

**ALSTOM**